

Vehicle Sales & Spares Army - Naval - Air Force

Registered Address: Suite G31 Genesis Centre, Innovation Way Stoke on Trent ST6 4BF, UK

Email: info@borecleaningsystems.com

Web: <https://borecleaningsystems.com>

Tele: +44 7464 727015

BCS
MILITARY VEHICLE SALES & SPARES



K2

TRACK SHOES FOR MAIN BATTLE TANK

- 1 Shoe Body
- 2 Pad Assembly
- 3 Pad Nut
- 4 Pin
- 5 End Connector
- 6 Wedge Nut
- 7 Wedge Bolt
- 8 Center Guide
- 9 Center Guide Cap
- 10 Guide Bolt
- 11 Guide Nut



• Vehicle Application	K2 MBT
• ASS'Y N.S.N	2530-37-516-6745
• Pitch (mm)	193.6
• Width (mm)	635.0
• Height (mm)	202.5
• Q'ty for 1 Vehicle	148

K1A1

TRACK SHOES FOR MAIN BATTLE TANK

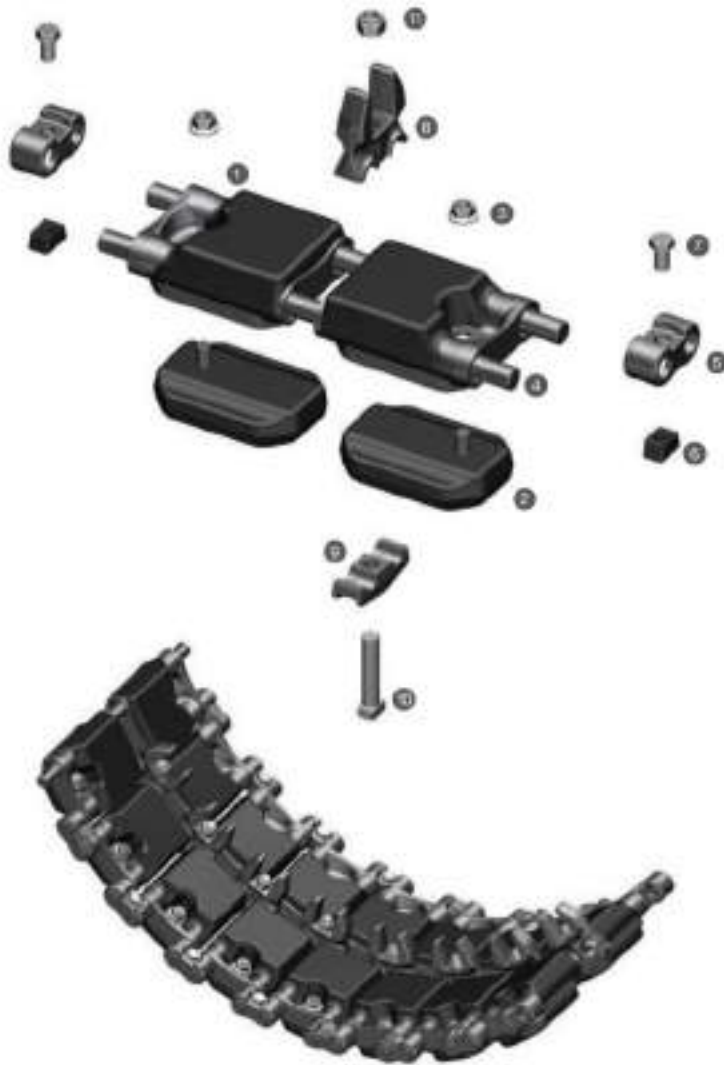

- 1 _ Shoe Body
- 2 _ Pad Assembly
- 3 _ Pad Nut
- 4 _ Pin
- 5 _ End Connector
- 6 _ Wedge Nut
- 7 _ Wedge Bolt
- 8 _ Center Guide
- 9 _ Center Guide Cap
- 10 _ Guide Bolt
- 11 _ Guide Nut

• Vehicle Application	K1A1 MBT
• ASSY N.S.N	2530-37-512-5268
• Pitch (mm)	193.6
• Width (mm)	635.0
• Height (mm)	196.4
• Q' ty for 1 Vehicle	152



K1

TRACK SHOES FOR MAIN BATTLE TANK

- 1 Shoe Body
- 2 Pin
- 3 End Connector
- 4 Wedge Bolt
- 5 Wedge Nut
- 6 Center Guide
- 7 Center Guide Cap
- 8 Guide Bolt
- 9 Guide Nut

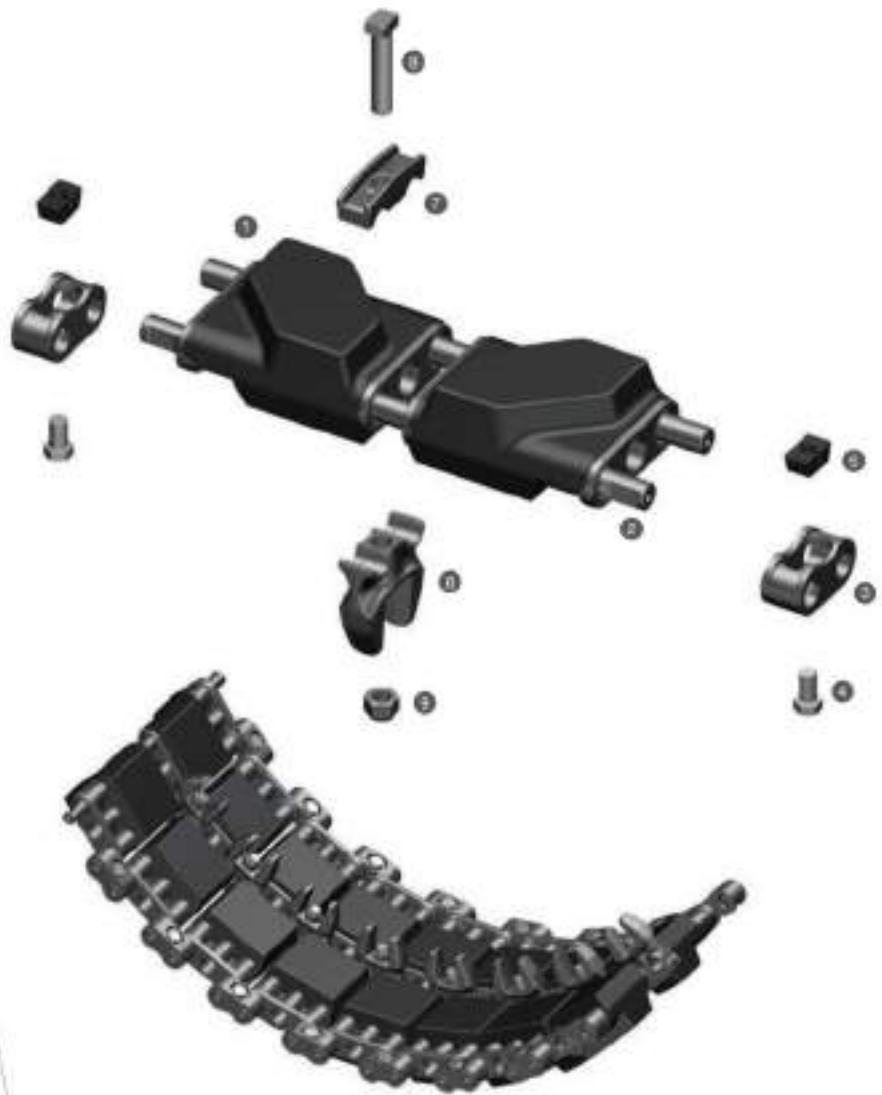

• Vehicle Application	K1, K1A1 MBT
• ASS'Y N.S.N	2530-37-501-1291
• Pitch (mm)	193.6
• Width (mm)	635.0
• Height (mm)	192.6
• Q' ty for 1 Vehicle	152

M60

TRACK SHOES FOR MAIN BATTLE TANK



- 1 _ Shoe Body
- 2 _ Pad Assembly
- 3 _ Pad Nut
- 4 _ Pin
- 5 _ End Connector
- 6 _ Wedge Nut
- 7 _ Wedge Bolt
- 8 _ Center Guide
- 9 _ Center Guide Cap
- 10 _ Guide Bolt
- 11 _ Guide Nut

- Model T142
- Vehicle Application M60 MBT
- ASSY N.S.N 2530-00-150-5897
- Pitch (mm) 176.2
- Width (mm) 711.0
- Height (mm) 226.4
- Q' ty for 1 Vehicle 160



T-80U

TRACK SHOES FOR MAIN BATTLE TANK

- 1 _ Shoe Body
- 2 _ Pin
- 3 _ Center Guide Bolt
- 4 _ Center Guide
- 5 _ Center Guide Cap
- 6 _ End Connector
- 7 _ Wedge Bolt (Screw)
- 8 _ Washer

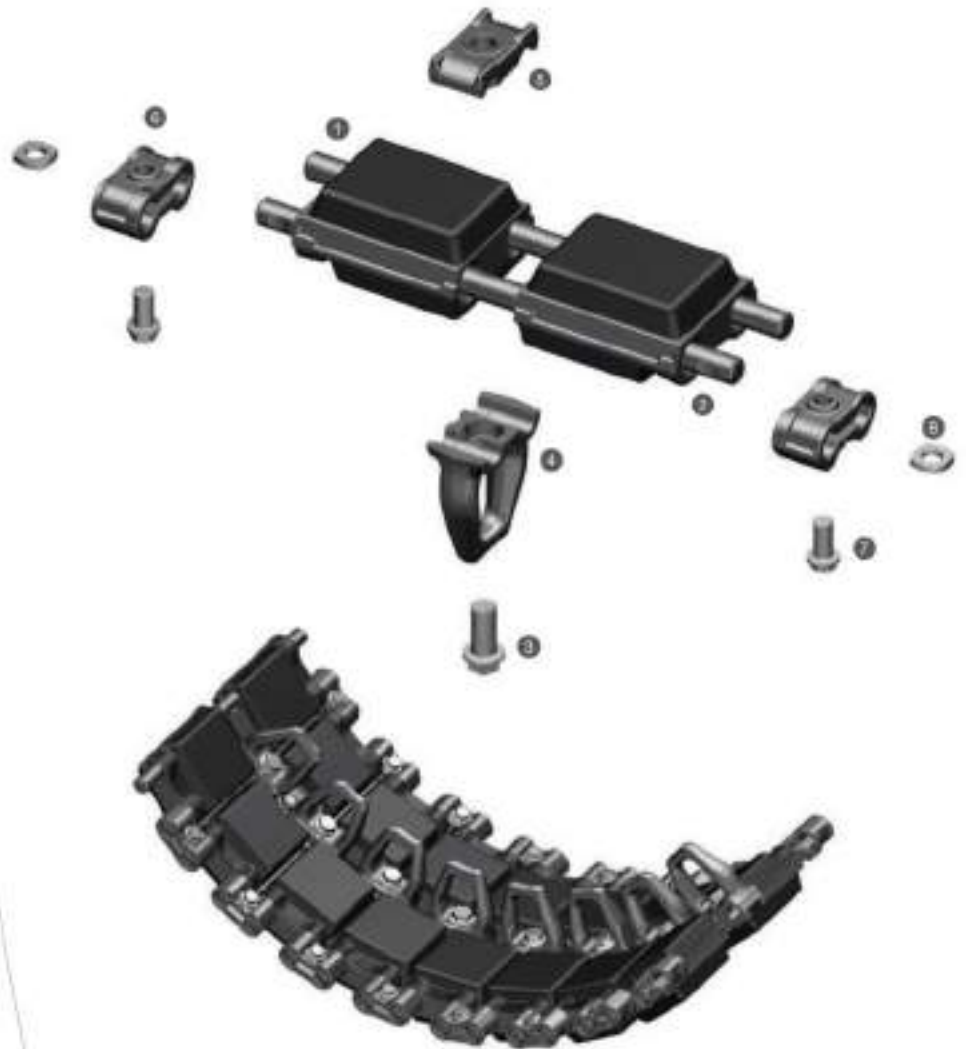

• Vehicle Application	T-80U MBT
• ASS'Y N.S.N	2530-37-518-2786
• Pitch (mm)	164.0
• Width (mm)	574.0
• Height (mm)	211.0
• Q'ty for 1 Vehicle	160

M47 & M48 & M88

TRACK SHOES FOR MAIN BATTLE TANK

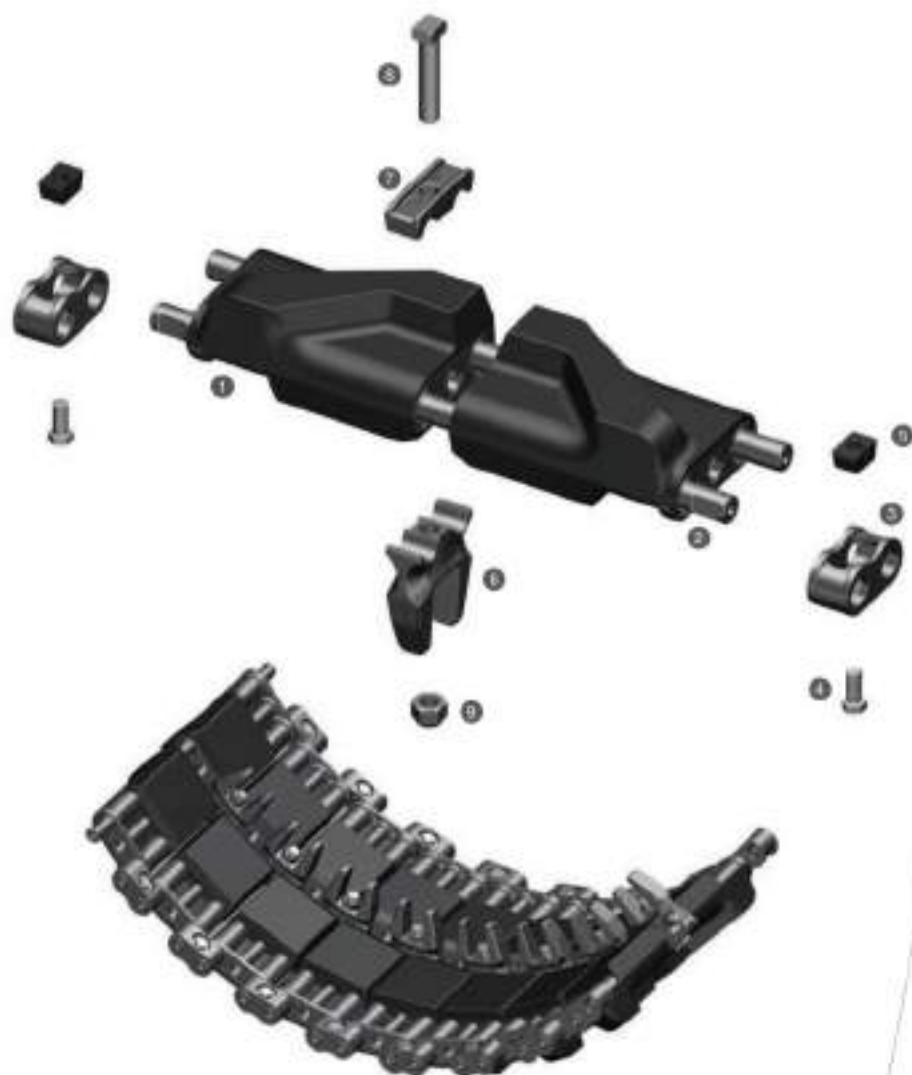

- 1 _ Shoe Body
- 2 _ Pin
- 3 _ End Connector
- 4 _ Wedge Bolt
- 5 _ Wedge Nut
- 6 _ Center Guide
- 7 _ Center Guide Cap
- 8 _ Guide Bolt
- 9 _ Guide Nut

• Model	T84E1	T97E2	T107
• Vehicle Application	M47 MBT	M48 MBT	M88A1 APV
• ASSY N.S.N	2530-00-704-9667	2530-00-337-8989	2530-00-692-9316
• Pitch (mm)	152.4	176.3	172.4
• Width (mm)	584.3	711.0	711.0
• Height (mm)	215.0	213.0	215.0
• Q' ty for 1 Vehicle	172	156	168



M113 & K200

TRACK SHOES FOR ARMORED PERSONNEL CARRIER

- 1 Shoe Body
- 2 Pad Assembly
- 3 Pad Nut
- 4 Pin
- 5 Pin Nut
- 6 Bushing (Long)
- 7 Bushing (Short)



- Model T130E1
- Vehicle Application M113A1, K200 APC Series
- ASS'Y N.S.N 2530-00-078-2908
- Pitch (mm) 152.4
- Width (mm) 381.0
- Height (mm) 150.0
- Q'ty for 1 Vehicle 127(M113) /128(K200)

K21

TRACK SHOES FOR INFANTRY FIGHTING VEHICLE



- 1_ Shoe Body
- 2_ Pad Assembly
- 3_ Pad Nut
- 4_ Pin
- 5_ End Connector
- 6_ Wedge Nut
- 7_ Wedge Bolt

• Vehicle Application	K21 IFV
• ASSY N.S.N	2530-37-513-6168
• Pitch (mm)	152.4
• Width (mm)	435.0
• Height (mm)	180.0
• Q' ty for 1 Vehicle	178



BMP-3

TRACK SHOES FOR INFANTRY FIGHTING VEHICLE

- 1 _ Shoe Body
- 2 _ End Connector
- 3 _ Pin
- 4 _ Pad Assembly
- 5 _ Center Guide
- 6 _ Center Guide Cap
- 7 _ Pad Bolt
- 8 _ Pad Nut
- 9 _ Center Guide Bolt
- 10 _ Wedge Bolt (Screw)



- Vehicle Application BMP-3 IFV
- ASS'Y N.S.N 9999-37-514-0873
- Pitch (mm) 150.0
- Width (mm) 381.0
- Height (mm) 178.0
- Q' ty for 1 Vehicle 174

AAV & MLRS & M2

TRACK SHOES FOR ARMORED PERSONNEL CARRIER



- 1_ Shoe Body
- 2_ Pad Assembly
- 3_ Pad Nut
- 4_ Pin
- 5_ Pin Nut
- 6_ Bushing (Long)
- 7_ Bushing (Short)



- Model T1571
- Vehicle Application — AAV-7A1 (Amphibious Assault Vehicle)
..... MLRS (Multiple Launch Rocket System)
..... M2 BRADLEY
- ASSY N.S.N 2530-01-288-2719
- Pitch (mm) 152.4
- Width (mm) 533.4
- Height (mm) 180.7
- Q' ty for 1 Vehicle 170(AAV) / 177(MLRS)



BIHO & CHUNMA

TRACK SHOES FOR ARMORED PERSONNEL CARRIER

- 1 Shoe Body
- 2 Pad Assembly
- 3 Pad Nut
- 4 Pin
- 5 End Connector
- 6 Wedge Nut
- 7 Wedge Bolt



- Model T154 Mod.
- Vehicle Application BIHO & CHUNMA Self-Propelled
Surface to Air Missile System
- ASS'Y N.S.N 2530-37-505-3168
- Pitch (mm) 152.4
- Width (mm) 458.0
- Height (mm) 170.1
- Q'ty for 1 Vehicle 170

M109 & K55

TRACK SHOES FOR SELF-PROPELLED HOWITZER



- 1 _ Shoe Body
- 2 _ Pad Assembly
- 3 _ Pad Nut
- 4 _ Pin
- 5 _ End Connector
- 6 _ Wedge Nut
- 7 _ Wedge Bolt

• Model T136
• Vehicle Application M109, K55 Self-Propelled Howitzer
• ASS'Y N.S.N 2530-00-799-0020
• Pitch (mm) 153.5
• Width (mm) 384.1
• Height (mm) 170.0
• Q' ty for 1 Vehicle 158



M107 & M110 & M578

TRACK SHOES FOR SELF-PROPELLED HOWITZER

- 1 Shoe Body
- 2 Pad Assembly
- 3 Pad Nut
- 4 Pin
- 5 Pin Nut
- 6 Bushing(Long)
- 7 Bushing(Short)



- Model T132E1
- Vehicle Application --- M107, M110 Self-Propelled Artillery
..... M578 Light Recovery Vehicle
- ASS'Y N.S.N 2530-00-076-7115
- Pitch (mm) 152.4
- Width (mm) 457.2
- Height (mm) 175.0
- Q'ty for 1 Vehicle 151

K9 & K10

TRACK SHOES FOR SELF-PROPELLED HOWITZER



- 1 _ Shoe Body
- 2 _ Pad Assembly
- 3 _ Pad Nut
- 4 _ Pin
- 5 _ End connector
- 6 _ Wedge Nut
- 7 _ Wedge Bolt
- 8 _ Center Guide
- 9 _ Center Guide Cap
- 10 _ Guide Bolt
- 11 _ Guide Nut

- Model LS-2
- Vehicle Application K9 Self-Propelled Howitzer
..... K10 Ammunition Resupply Vehicle
- ASS'Y N.S.N 2530-37-505-6982
- Pitch (mm) 160.0
- Width (mm) 548.0
- Height (mm) 176.3
- Q' ty for 1 Vehicle 186



K55A1

TRACK SHOES FOR SELF-PROPELLED HOWITZER

- 1 Shoe Body
- 2 Pad Assembly
- 3 Pad Nut
- 4 Pin
- 5 End Connector
- 6 Wedge Nut
- 7 Wedge Bolt



- Vehicle Application K55A1 SPH
- ASS'Y N.S.N 2530-37-520-3490
- Pitch (mm) 153.5
- Width (mm) 379.5
- Height (mm) 180.5
- Q' ty for 1 Vehicle 158

M9ACE(C66)

TRACK SHOES FOR DOZERS

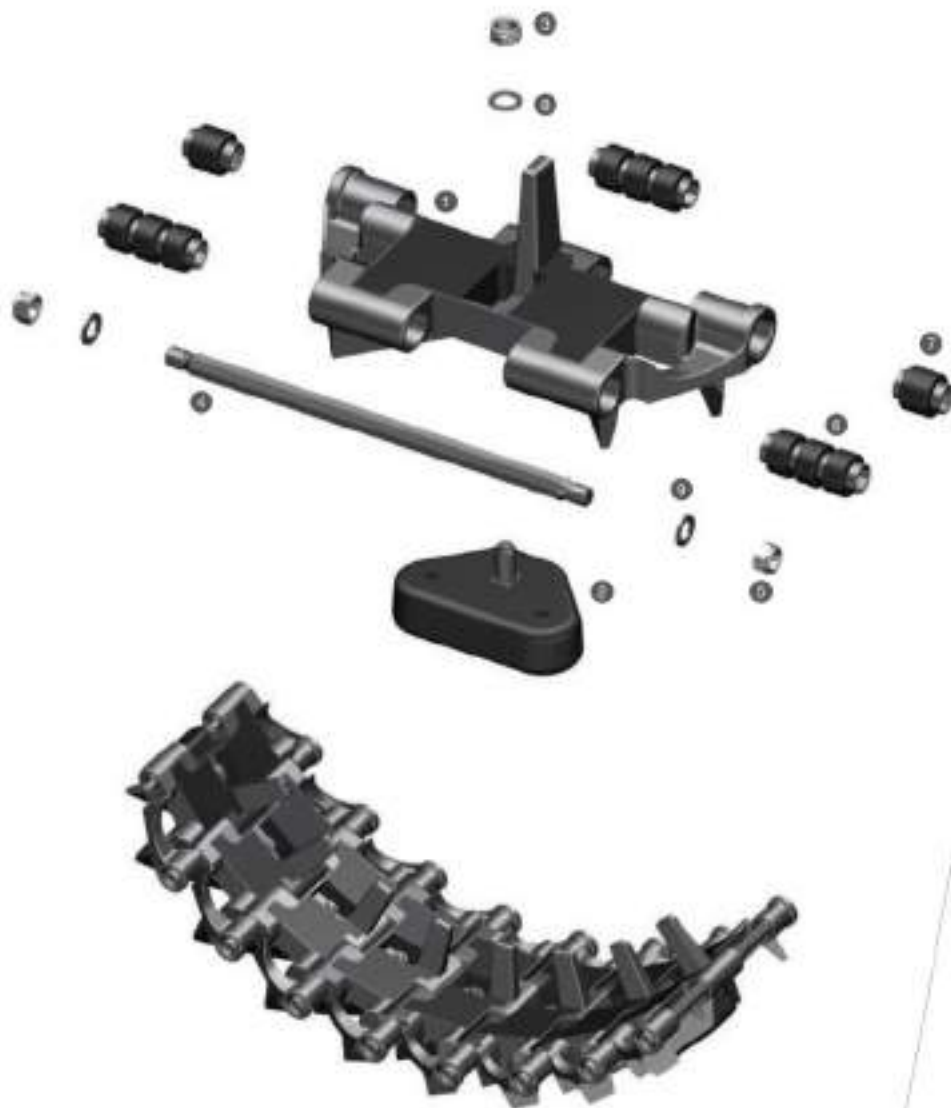

- 1 _ Shoe Body
- 2 _ Pad Assembly
- 3 _ Pad Nut
- 4 _ Pin
- 5 _ Pin Nut
- 6 _ Bushing(Long)
- 7 _ Bushing(Short)
- 8 _ Washer(Pad)
- 9 _ Washer(Pin)



• Model	T164
• Vehicle Application	M9ACE(C66) Combat Dozer
• ASSY N.S.N	2530-01-234-1917
• Pitch (mm)	152.4
• Width (mm)	457.2
• Height (mm)	207.4
• Q'ty for 1 Vehicle	116



PRODUCTS LIST

Track Shoes for MBT	Track Shoes for APC & IFV	Track Shoes for SPH	Others
<ul style="list-style-type: none"> * K2 * K1A1 * K1 * M60 (T142) * T-80U * M47 (T84E1) * M48 (T97E2) * M88 (T107) 	<ul style="list-style-type: none"> * M113 & K200 (T130E1) * K21 * BMP-3 * AAV & MLRS (T157) * BIHO & CHUNMA (T154Mod.) 	<ul style="list-style-type: none"> * M109 & K55 (T136) * M107 & M110 & M578 (T132E1) * K9 & K10 	<ul style="list-style-type: none"> * Merkava * M9 & M60 * M1 & M-2 Abrams * Leopard 1 & 2 * M9ACE (T1640) * LVTP 7 & AMX-113



Vehicle Sales & Spares Army - Naval - Air Force

Registered Address: Suite G31 Genesis Centre, Innovation Way Stoke on Trent ST6 4BF, UK

Email: info@borecleaningsystems.com

Web: <https://borecleaningsystems.com>

Tele: +44 7464 727015

BCS

MILITARY VEHICLE SALES & SPARES